

# Drum Filter System

---

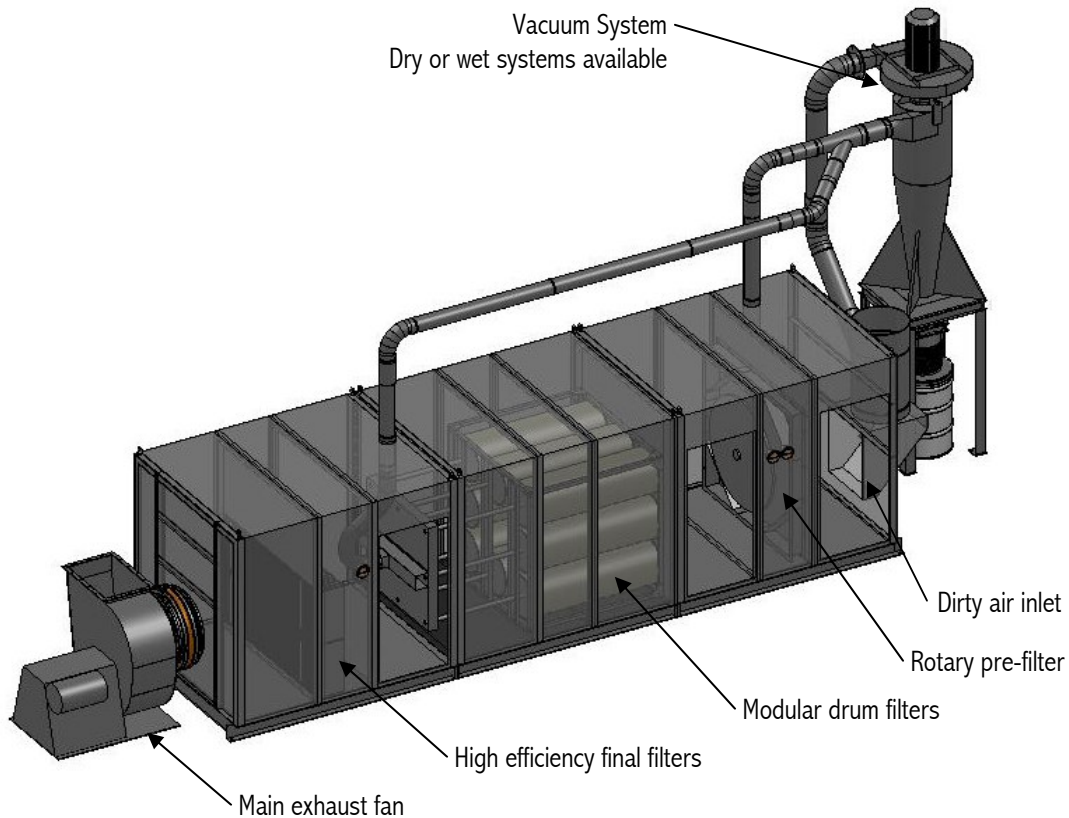

## Features include:

- Dry system - cleaned air is returned to machine room reducing energy costs
- Simple design - easy to understand and maintain
- Modular design is completely factory assembled and wired reducing field installation time and cost
- Modular design can be broken down for shipping on standard loads also simplifying handling at job site
- Rotary pre-filter collects tissue broke for recycling also preventing plugging of drum filters
- Modular drum filters are more compact than conventional drum filters requiring less floor space
- High efficiency final filters remove fine dust to insure quality of return air
- Automatic vacuum system removes tissue broke from rotary pre-filter and dust from drum filters. The vacuum flow rate is typically less than 10% of the exhaust flow entering the drum filter assembly.
- Vacuum system can be furnished with either dry or wet dust collector for removing tissue dust from the vacuum air.

***EnviroAir Inc.***